



**INSTITUTO DE CIENCIAS
DE LA CONSTRUCCIÓN
EDUARDO TORROJA**

C/ Serrano Galvache n. 4 28033 Madrid (Spain)
Tel.: (34) 91 302 04 40 Fax: (34) 91 302 07 00
direccion.ietcc@csic.es www.ietcc.csic.es

European Technical Assessment

**ETA 05 / 0242
of 07 /12 / 2016**

English translation prepared by IETcc. Original version in Spanish language

General Part

Technical Assessment Body issuing the ETA designated according to Art. 29 of Regulation (EU) 305/2011:

Instituto de Ciencias de la Construcción Eduardo Torroja (IETcc)

Trade name of the construction product

**Anchor MTH
Anchor MTH-A4**

Product family to which the construction product belongs

Torque controlled expansion anchor made of galvanised steel or stainless steel of sizes M6, M8, M10, M12, M14, M16 and M20 for use in non-cracked concrete.

Manufacturer

Index - Técnicas Expansivas S.L.
Segador 13
26006 Logroño (La Rioja) Spain.
website: www.indexfix.com

Manufacturing plants

Index plant 2
Index plant 3

This European Technical Assessment contains

13 pages including 4 annexes which form an integral part of this assessment. **Annex E contains confidential information and is not included in the European Technical Assessment when that assessment is publicly available.**

This European Technical Assessment is issued in accordance with regulation (EU) No 305/2011, on the basis of

Guideline for European Technical Approval ETAG 001 "Metal anchors for use in concrete", ed. April 2013, Parts 1 and 2 used as European Assessment Document (EAD)

This version replaces

ETA 05/0242 issued on 08/09/2014

Translations of this European Technical Assessment in other languages shall fully correspond to the original issued document and should be identified as such.

This European Technical Assessment may be withdrawn by the issuing Technical Assessment Body, in particular pursuant to information by the Commission according to article 25 paragraph 3 of Regulation (EU) No 305/2011.

SPECIFIC PART

1. Technical description of the product

The Index MTH in the range of M6 to M20 is an anchor made of galvanised steel. The Index MTH-A4 in the range of M6 to M20 is an anchor made of stainless steel. Both are placed into a drilled hole and anchored by torque-controlled expansion.

The Index MTH/MTH-A4 anchors in the range of M6 to M20 correspond to the picture and provisions given in annexes A and B. The characteristic material values, dimensions and tolerances of the anchors not indicated in annexes A and B shall correspond to the respective values laid down in the technical documentations⁽¹⁾ of this European Technical Assessment.

For the installation process see figure given in annex C; for the installed anchor see figure given in annex D.

Each expansion sleeve is marked with the identifying mark of the producer, the trade name and the anchor diameter; each anchor bolt is marked with the diameter (metric) and the total anchor length. A red colour ring(s) marking identifies the embedment depth(s).

The performance of the anchors, including installation data, characteristic anchor values, displacements and fire resistance, for the design of anchorages is given in chapter 3.

The anchors shall only be packaged and supplied as a complete unit.

2. Specification of the intended use in accordance with the applicable EAD.

2.1 Intended use

The anchors are intended to be used for anchorages for which requirements for mechanical resistance and stability and safety and accessibility in use in the sense of the basic requirements 1 and 4 of Construction Product Regulation no 305/21011 shall be fulfilled and failure of anchorages made with these products would compromise the stability of the works, cause risk to human life and/or lead to considerable economic consequences.

The anchors are to be used only for anchorages subject to static or quasi-static loading in reinforced or unreinforced normal weight concrete of strength class C20/25 to C50/60, according to EN 206. It may be anchored in non-cracked concrete only.

The Index MTH anchor may only be used in concrete subject to dry internal conditions.

The Index MTH-A4 anchor may be used in concrete subject to dry internal conditions and also in concrete subject to external atmospheric exposure (including industrial and marine environments), or exposure in permanently damp internal conditions, if no particular aggressive conditions exist. Such particular aggressive conditions are e.g. permanent, alternating immersion in seawater or the splash zone of seawater, chloride atmosphere of indoor swimming pools or atmosphere with extreme chemical pollution (e.g. in desulphurization plants or road tunnels where de-icing materials are used).

The provisions made in this European Technical Assessment are based on an assumed working life of the anchor of 50 years. The assumed working life is the foreseen period of time throughout which the construction product, as installed into the construction work, will keep its performances

(1) The quality plan has been deposited at Instituto de ciencias de la construcción Eduardo Torroja and is only made available to the approved bodies involved in the AVCP procedure.

allowing the construction work, behaving under predictable actions and with normal maintenance, to meet the basic requirements for construction works.

3. Performance of the product and references to the methods used for its assessment

The identification tests and the assessment for the intended use of this anchor according to the Basic Work Requirements (BWR) were carried out in compliance with the ETAG 001. The characteristics of the components shall correspond to the respective values laid down in the technical documentation of this ETA, checked by IETcc.

3.1 Mechanical resistance and stability (BWR 1)

Mechanical resistance and stability has been assessed according to ETAG 001 “Metal anchors to be used in concrete”, parts 1 and 2.

MTH: GALVANISED ANCHOR Installation parameters			Performances						
			M6	M8	M10	M12	M14	M16	M20
d_o	Nominal diameter of drill bit:	[mm]	6	8	10	12	14	16	20
d_f	Fixture clearance hole diameter:	[mm]	7	9	12	14	16	18	22
T_{inst}	Nominal installation torque:	[Nm]	7	20	35	60	90	120	240
Standard embedment depth									
L_{min}	Total length of the bolt:	[mm]	60	75	85	100	120	125	160
L_{max}		[mm]	180	155	230	250	250	280	270
h_{min}	Minimum thickness of concrete member:	[mm]	100	100	110	130	150	168	206
h_1	Depth of drilled hole:	[mm]	55	65	75	85	100	110	135
h_{nom}	Overall anchor embed depth in concrete:	[mm]	49.5	59.5	66.5	77	91	103.5	125
$h_{ef, std}$	Effective anchorage depth:	[mm]	40	48	55	65	75	84	103
t_{fix}	Thickness of fixture for DIN 125 washer**	[mm]	L-58	L-70	L-80	L-92	L-108	L-122	L-147
t_{fix}	Thickness of fixture for DIN 9021 and 440 washers**	[mm]	L-58	L-71	L-80	L-94	L-108	L-124	L-149
s_{min}	Minimum allowable spacing:	[mm]	50	65	70	85	100	110	135
c_{min}	Minimum allowable distance:	[mm]	50	65	70	85	100	110	135
Reduced embedment depth									
L_{min}	Total length of the bolt:	[mm]	--	60	70	80	--	--	--
L_{max}		[mm]	--	155	230	250	--	--	--
h_{min}	Minimum thickness of concrete member:	[mm]	--	100	100	100	--	--	--
h_1	Depth of drilled hole:	[mm]	--	50	60	70	--	--	--
h_{nom}	Overall anchor embed depth in concrete:	[mm]	--	46.5	53.5	62	--	--	--
$h_{ef, red}$	Effective anchorage depth:	[mm]	--	35 ^{*)}	42	50	--	--	--
t_{fix}	Thickness of fixture:	[mm]	--	L-57	L-67	L-77	--	--	--
s_{min}	Minimum allowable spacing:	[mm]	--	65	70	85	--	--	--
c_{min}	Minimum allowable distance:	[mm]	--	65	70	85	--	--	--

^{*)} Use restricted to anchoring of structural components which are statically indeterminate

^{**)} L = total anchor length

MTH: GALVANISED ANCHOR Characteristic values of resistance to tension loads of design method A		Performances							
		M6	M8	M10	M12	M14	M16	M20	
STEEL FAILURE									
$N_{Rk,s}$	Characteristic resistance:	[kN]	7.7	16.4	25.6	35.4	51.7	65.0	104.4
$\gamma_{M,s}$	Partial safety factor: ****)	[-]	1.40	1.40	1.40	1.43	1.43	1.43	1.47
PULL OUT FAILURE									
Standard embedment depth									
$N_{Rk,p}$	Char. resistance in C20/25 non cracked concrete:	[kN]	-- **)	12	16	25	30	35	50
$\gamma_{M,p}$	Partial safety factor: ****)	[-]	--	1.5	1.8	1.8	1.8	1.8	1.8
Reduced embedment depth									
$N_{Rk,p}$	Char. resistance in C20/25 non cracked concrete:	[kN]	-- **)	9 *)	12	16	--	--	--
$\gamma_{M,p}$	Partial safety factor: ****)	[-]	--	1.5	1.5	1.5	--	--	--
Ψ_c	Increasing factors for both embedment depths:	C30/37				1.22			
Ψ_c		C40/50				1.41			
Ψ_c		C50/60				1.55			
CONCRETE CONE FAILURE AND SPLITTING FAILURE									
Standard embedment depth									
$h_{ef, std}$	Effective anchorage depth:	[mm]	40	48	55	65	75	84	103
$N_{Rk,c}$	Characteristic resistance in C20/25 non cracked concrete:	[kN]	12.7	16.7	20.5	26.4	32.7	38.8	52.6
$\gamma_{M,c=}$ $\gamma_{M,sp}$	Partial safety factor: ****)	[-]	1.5	1.5	1.8	1.8	1.8	1.8	1.8
$s_{cr,N}$	Spacing:	[mm]	120	144	165	195	225	252	309
$s_{cr,sp}$		[mm]	160	192	220	260	300	336	412
$c_{cr,N}$	Edge distance:	[mm]	60	72	83	98	113	126	155
$c_{cr,sp}$		[mm]	80	96	110	130	150	168	206
Reduced embedment depth									
$h_{ef, std}$	Effective anchorage depth:	[mm]	--	35 *)	42	50	--	--	--
$N_{Rk,c}$	Characteristic resistance in C20/25 non cracked concrete:	[kN]	--	10.4	13.7	17.8	--	--	--
$\gamma_{M,c=}$ $\gamma_{M,sp}$	Partial safety factor: ****)	[-]	--	1.5	1.5	1.5	--	--	--
$s_{cr,N}$	Spacing:	[mm]	--	105	126	150	--	--	--
$s_{cr,sp}$		[mm]	--	140	168	200	--	--	--
$c_{cr,N}$	Edge distance:	[mm]	--	53	63	75	--	--	--
$c_{cr,sp}$		[mm]	--	70	84	100	--	--	--
Ψ_c	Increasing factor:	C30/37				1.22			
Ψ_c		C40/50				1.41			
Ψ_c		C50/60				1.55			

*) Use restricted to anchoring of structural components which are statically indeterminate

**) Pull out failure is not decisive

****) In absence of other national regulations

MTH: GALVANISED ANCHOR Displacements under tension loads in C20/25 to C50/60 concrete		Performances							
		M6	M8	M10	M12	M14	M16	M20	
Standard embedment depth									
	Tension load in non cracked concrete:	[kN]	2.8	5.0	6.0	9.3	10.7	16.0	17.0
δ_{N0}	Displacement:	[mm]	0.70	1.12	1.07	1.32	1.82	2.38	3.56
$\delta_{N\infty}$		[mm]	1.47	2.34	2.24	2.77	3.82	4.99	7.47
Reduced embedment depth									
	Tension load in non cracked concrete:	[kN]	--	4.2	5.7	7.6	--	--	--
δ_{N0}	Displacement:	[mm]	--	0.20	0.13	0.06	--	--	--
$\delta_{N\infty}$		[mm]	--	1.78	1.78	1.78	--	--	--

MTH: GALVANISED ANCHOR Characteristic values of resistance to shear loads of design method A				Performances					
				M6	M8	M10	M12	M14	M16
STEEL FAILURE WITHOUT LEVER ARM									
$V_{Rk,s}$	Characteristic resistance:	[kN]	5.1	9.3	14.7	20.6	28.1	38.4	56.3
$\gamma_{M,s}$	Partial safety factor: ^{*)}	[-]	1.25						
STEEL FAILURE WITH LEVER ARM									
$M_{Rk,s}^0$	Characteristic bending moment:	[Nm]	7.7	19.1	38.1	64.1	102.2	163.1	298.5
$\gamma_{M,s}$	Partial safety factor: ^{*)}	[-]	1.25						
CONCRETE PRYOUT RESISTANCE									
k	Factor in equation (5.6) of	for $h_{ef,std}$	[-]	1.0	1.0	1.0	2.0	2.0	2.0
k	ETAG, Annex C §5.2.3.3:	for $h_{ef,red}$	[-]	--	1.0	1.0	1.0	--	--
$\gamma_{M,c}$	Partial safety factor: ^{**)}	[-]	1.5						
CONCRETE EDGE FAILURE									
l_f	Effective length of anchor	for $h_{ef,std}$	[mm]	40	48	55	65	75	84
l_f	under shear loads:	for $h_{ef,red}$	[mm]	--	35 ^{*)}	42	50	--	--
d_{nom}	Outside diameter of anchor:		[mm]	6	8	10	12	14	16
$\gamma_{M,c}$	Partial safety factor: ^{**)}	[-]	1.5						

^{*)} Use restricted to anchoring of structural components which are statically indeterm. ^{**)} In absence of other national regulat..

MTH: GALVANISED ANCHOR Displacements under shear loads in C20/25 to C50/60 concrete				Performances					
				M6	M8	M10	M12	M14	M16
Standard embedment depth									
	Shear load in non cracked concrete:	[kN]	2.9	5.3	8.4	11.8	16.0	21.9	32.1
δ_{V0}	Displacement:	[mm]	0.65	2.80	1.75	2.45	2.78	3.53	4.13
$\delta_{V\infty}$		[mm]	0.98	4.20	2.63	3.68	4.16	5.29	6.19
Reduced embedment depth									
	Shear load in non cracked concrete:	[kN]	--	5.3	8.4	11.8	--	--	--
δ_{V0}	Displacement:	[mm]	--	0.59	1.22	1.10	--	--	--
$\delta_{V\infty}$		[mm]	--	0.89	1.83	1.65	--	--	--

MTH-A4: STAINLESS STEEL ANCHOR Installation parameters				Performances					
				M6	M8	M10	M12	M16	M20
d_o	Nominal diameter of drill bit:	[mm]	6	8	10	12	16	20	
d_f	Fixture clearance hole diameter:	[mm]	7	9	12	14	18	22	
T_{inst}	Nominal installation torque:	[Nm]	7	20	35	60	120	240	
Standard embedment depth									
L_{min}	Total length of the bolt:	[mm]	60	75	85	100	125	160	
L_{max}		[mm]	180	155	170	180	170	220	
h_{min}	Minimum thickness of concrete member:	[mm]	100	100	110	130	168	206	
h_1	Depth of drilled hole:	[mm]	55	65	75	85	110	135	
h_{nom}	Overall anchor embed depth in concrete:	[mm]	49.5	59.5	66.5	77	103.5	125	
$h_{ef,std}$	Effective anchorage depth:	[mm]	40	48	55	65	84	103	
t_{fix}	Thickness of fixture	[mm]	L-58	L-70	L-80	L-92	L-122	L-147	
s_{min}	Minimum allowable spacing:	[mm]	50	65	70	85	110	135	
c_{min}	Minimum allowable distance:	[mm]	50	65	70	85	110	135	
Reduced embedment depth									
L_{min}	Total length of the bolt:	[mm]	--	60	70	80	--	--	
L_{max}		[mm]	--	155	170	180	--	--	
h_{min}	Minimum thickness of concrete member:	[mm]	--	100	100	100	--	--	
h_1	Depth of drilled hole:	[mm]	--	50	60	70	--	--	
h_{nom}	Overall anchor embed depth in concrete:	[mm]	--	46.5	53.5	62	--	--	
$h_{ef,red}$	Effective anchorage depth:	[mm]	--	35 ^{*)}	42	50	--	--	
t_{fix}	Thickness of fixture	[mm]	--	L-57	L-67	L-77	--	--	
s_{min}	Minimum allowable spacing:	[mm]	--	65	70	85	--	--	
c_{min}	Minimum allowable distance:	[mm]	--	65	70	85	--	--	

^{*)} Use restricted to anchoring of structural components which are statically indeterminate

MTH-A4: STAINLESS STEEL ANCHOR Characteristic values of resistance to tension loads of design method A		Performances						
		M6	M8	M10	M12	M16	M20	
STEEL FAILURE								
$N_{Rk,s}$	Characteristic resistance:	[kN]	10.1	19.1	34.3	49.6	85.9	140.7
$\gamma_{M,s}$	Partial safety factor: ***)	[-]	1.68					
PULL OUT FAILURE								
Standard embedment depth								
$N_{Rk,p}$	Char. resistance in C20/25 non cracked concrete:	[kN]	-- **)	12	16	25	35	50
$\gamma_{M,p}$	Partial safety factor: ***)	[-]	--	1.5	1.8	1.8	1.8	1.8
Reduced embedment depth								
$N_{Rk,p}$	Char. resistance in C20/25 non cracked concrete:	[kN]	--	9 *)	12	16	--	--
$\gamma_{M,p}$	Partial safety factor: ***)	[-]	--	1.8	1.8	1.8	--	--
Ψ_c	Increasing factors for both embedment depths:	C30/37	1.22					
Ψ_c		C40/50	1.41					
Ψ_c		C50/60	1.55					
CONCRETE CONE FAILURE								
Standard embedment depth								
$h_{ef, std}$	Effective anchorage depth:	[mm]	40	48	55	65	84	103
$N_{Rk,c}$	Characteristic resistance in C20/25 non cracked concrete:	[kN]	12.7	16.7	20.5	26.4	38.8	52.6
$\gamma_{M,c=}$ $\gamma_{M,sp}$	Partial safety factor: ***)	[-]	1.5	1.5	1.8	1.8	1.8	1.8
$s_{cr,N}$	Spacing:	[mm]	120	144	165	195	252	309
$s_{cr,sp}$		[mm]	160	192	220	260	336	412
$c_{cr,N}$	Edge distance:	[mm]	60	72	83	98	126	155
$c_{cr,sp}$		[mm]	80	96	110	130	168	206
Reduced embedment depth								
$h_{ef, std}$	Effective anchorage depth:	[mm]	--	35 *)	42	50	--	--
$N_{Rk,c}$	Characteristic resistance in C20/25 non cracked concrete:	[kN]	--	10.4	13.7	17.8	--	--
$\gamma_{M,c=}$ $\gamma_{M,sp}$	Partial safety factor: ***)	[-]	--	1.8	1.8	1.8	--	--
$s_{cr,N}$	Spacing:	[mm]	--	105	126	150	--	--
$s_{cr,sp}$		[mm]	--	140	168	200	--	--
$c_{cr,N}$	Edge distance:	[mm]	--	53	63	75	--	--
$c_{cr,sp}$		[mm]	--	70	84	100	--	-
Ψ_c	Increasing factor:	C30/37	1.22					
Ψ_c		C40/50	1.41					
Ψ_c		C50/60	1.55					

*) Use restricted to anchoring of structural components which are statically indeterminate

***) Pull out failure is not decisive

****) In absence of other national regulations

MTH-A4: STAINLESS STEEL ANCHOR Displacements under tension loads in C20/25 to C50/60 concrete		Performances						
		M6	M8	M10	M12	M16	M20	
Standard embedment depth								
	Tension load in non cracked concrete:	[kN]	4.3	5.7	6.3	9.9	13.8	19.8
δ_{N0}	Displacement:	[mm]	0.42	0.22	0.17	0.19	0.19	0.11
$\delta_{N\infty}$		[mm]	1.33	1.33	1.33	1.33	1.33	1.33
Reduced embedment depth								
	Tension load in non cracked concrete:	[kN]	--	4.2	5.7	7.6	--	--
δ_{N0}	Displacement:	[mm]	--	0.07	0.04	0.32	--	--
$\delta_{N\infty}$		[mm]	--	0.60	0.60	0.60	--	--

MTH-A4: STAINLESS STEEL ANCHOR Characteristic values of resistance to shear loads of design method A				Performances					
				M6	M8	M10	M12	M16	M20
STEEL FAILURE WITHOUT LEVER ARM									
$V_{Rk,s}$	Characteristic resistance:	[kN]	6.0	10.9	17.4	25.2	47.1	73.5	
$\gamma_{M,s}$	Partial safety factor	[-]	1.52						
STEEL FAILURE WITH LEVER ARM									
$M_{Rk,s}^0$	Characteristic bending moment:	[Nm]	9.2	22.5	44.9	78.6	200	389	
$\gamma_{M,s}$	Partial safety factor: **)	[-]	1.52						
CONCRETE PRYOUT FAILURE									
k	Factor in equation (5.6) of	for $h_{ef, std}$	[-]	1.0	1.0	1.0	2.0	2.0	2.0
k	ETAG, Annex C §5.2.3.3:	for $h_{ef, red}$	[-]	--	1.0 ¹⁾	1.0	1.0	--	--
$\gamma_{M,c}$	Partial safety factor: **)	[-]	1.5						
CONCRETE EDGE FAILURE									
l_f	Effective length of anchor	for $h_{ef, std}$	[mm]	40	48	55	65	84	103
l_f	under shear loads:	for $h_{ef, red}$	[mm]	--	35 ^{*)}	42	50	--	--
d_{nom}	Outside diameter of anchor:		[mm]	6	8	10	12	16	20
$\gamma_{M,c}$	Partial safety factor: **)	[-]	1.5						

¹⁾ Use restricted to anchoring of structural components which are statically indeterminate

^{**) In absence of other national regulations}

MTH-A4: STAINLESS STEEL ANCHOR Displacements under shear loads in C20/25 to C50/60 concrete				Performances				
				M6	M8	M10	M12	M16
Standard embedment depth								
	Shear load in non cracked concrete:	[kN]	2.8	5.1	8.1	11.8	22.1	34.5
δ_{V0}	Displacement:	[mm]	1.66	1.79	3.83	4.13	5.75	6.59
$\delta_{V\infty}$		[mm]	2.49	2.68	5.74	6.19	8.62	9.88
Reduced embedment depth								
	Shear load in non cracked concrete:	[kN]	--	5.1	8.1	11.8	--	--
δ_{V0}	Displacement:	[mm]	--	0.60	3.83	4.13	--	--
$\delta_{V\infty}$		[mm]	--	0.90	5.74	6.19	--	--

3.2 Safety in case of fire (BWR 2)

Reaction to fire has been assessed according to Commission Decision 96/603/EC, amended by 2000/605/EC. See class in table below:

Reaction to fire	M6	M8	M10	M12	M14	M16	M20
Anchor MTH Anchor MTH-A4	Class A1						

Resistance to fire: No Performance Determined

3.3 Hygiene, health and the environment (BWR 3)

This requirement is not relevant for the anchors.

3.4 Safety in use (BWR 4)

Requirements with respect to the safety in use are not included in this Essential Requirement but are treated under the Essential Requirement Mechanical Resistance and Stability (see section 3.1)

3.5 Protection against noise (BWR 5)

This requirement is not relevant for the anchors.

3.6 Energy economy and heat retention (BWR 6)

This requirement is not relevant for the anchors.

3.7 Sustainable use of natural resources (BWR 7)

No Performance Determined

4. Assessment and verification of constancy of performance (hereinafter AVCP) system applied, with reference to its legal base

According to the decision 96/582/EC of the European Commission ⁽²⁾ the system of assessment and verification of constancy of performance (see Annex V to Regulation (EU) No 305/2011) given in the following table applies:

Product	Intended use	Level or class	System
Index MTH anchor Index MTH-A4 anchor	To be used for fixing and/or supporting structural elements	All / any	1

The system 1 referred above is described in Construction Products Regulation (EU) no. 305/211 Annex V §. 1.3 as follows:

- a) The manufacturer shall carry out:
 - (i.) Factory production control.
 - (ii.) Further testing of samples taken at the factory by the manufacturer in accordance with the prescribed quality plan;
- b) The notified production control certification body shall issue the certificate of conformity of the factory production control on the basis of:
 - (i.) Determination of the product-type on the basis of type testing (including sampling) calculation, tabulated values of descriptive documentation of the product.
 - (ii.) Initial inspection of factory and of factory production control.
 - (iii.) Continuous surveillance, assessment and evaluation of factory production

5. Technical details necessary for the implementation of the AVCP system, as provided for in the applicable EAD

The ETA is issued for this anchor on the basis of agreed data/information which identifies the product that has been assessed and judged. Detailed description and conditions of the manufacturing process of the anchor, and all the relevant design and installation criteria of this anchor are specified in the manufacturer's technical documentation deposited with the IETcc. The main aspects of this information are specified in the following sections. It is the manufacturer's responsibility to make sure that all those who use the anchor are appropriately informed of specific conditions according to sections 1, 2, 4 and 5 including the annexes of this ETA.

5.1 Tasks of the manufacturer

5.1.1 Factory production control

(2) Published in the Official Journal of the European Union (OJEU) L254 of 24.06.1996 See www.new.eur-lex.europa.eu/oj/direct-access.html

The manufacturer has a factory production control system and shall exercise permanent internal control of production. All the elements, requirements and provisions adopted by the manufacturer shall be documented in a systematic manner in the form of written policies and procedures, including records of results performed. This production control system shall insure that the product is in conformity with this ETA.

The manufacturer shall only use raw materials supplied with the relevant inspection documents as laid down in the quality plan⁽³⁾. The incoming raw materials shall be subjected to controls by the manufacturer before acceptance. Check of materials shall include control of the inspection documents presented by suppliers by verifying dimension and material properties, e.g. chemical composition, mechanical properties etc. The manufactured components are checked visually, for dimensions and properties, where appropriate.

The quality plan which is part of the Technical Documentation of this ETA, includes details of the extent, nature and frequency of testing and controls to be performed within the factory production control and has been agreed between the assessment holder and IETcc. The results of factory production control shall be recorded and evaluated in accordance with the provisions of the quality plan. The records include at least the following information:

- Designation of the product, the basic materials and components;
- Type of control or testing and minimum frequencies of them;
- Date of manufacture of the product and date testing of the product or basic material and components;
- Results of controls and testing and, if appropriate, comparison with requirements;
- Signature of person responsible for factory production control.

The records shall be presented to the notified body involved in the continuous surveillance. On request, they shall be presented to the IETcc.

5.2 Tasks of notified bodies

5.2.1 Determination of the product-type on the basis of type testing

For type-testing the results of the tests performed as part of the assessment for the European Technical Assessment shall be used unless there are changes in the production line or plant. In such cases the necessary type testing has to be agreed between ETA holder and the notified body.

5.2.2 Initial inspection of factory and of factory production control

The notified body shall ascertain that, in accordance with the quality plan, the factory and the factory production control are suitable to ensure continuous and orderly manufacturing of the product according to the specifications mentioned in Annexes of this the European Technical Assessment.

5.2.3 Continuous surveillance

The notified body shall visit the factory at least once a year for regular inspection.

This continuous surveillance and assessment of factory production control have to be performed according to the quality plan. The system of factory production control and the specified manufacturing process has to be verified that they are maintained as the quality plan defined. The results of product certification and continuous surveillance shall be made available on demand by the product certification body or factory production control body, respectively, to IETcc. In cases where

⁽³⁾ the quality plan has been deposited at IETcc and is only made available to the approval bodies involved in the ACVP procedure.

the provisions of the European Technical Assessment and the quality plan are no longer fulfilled the conformity certificate shall be withdrawn.



Instituto de ciencias de la construcción Eduardo Torroja
CONSEJO SUPERIOR DE INVESTIGACIONES CIENTÍFICAS

C/ Serrano Galvache n.º 4. 28033 Madrid.
Tel: (+34) 91 302 04 40 Fax. (+34) 91 302 07 00
www.ietcc.csic.es



On behalf of the Instituto de Ciencias de la Construcción Eduardo Torroja
Madrid, 7th December 2016

A handwritten signature in black ink, appearing to read 'Marta Castellote', with a long horizontal line extending to the right.

Marta M^a Castellote Armero
Director

INDEX OF ANNEXES:

Annex A: Assembled anchor

Annex B. Materials

Annex C. Installation process

Annex D. Schema of the anchor in use

Annex A: Assembled anchor

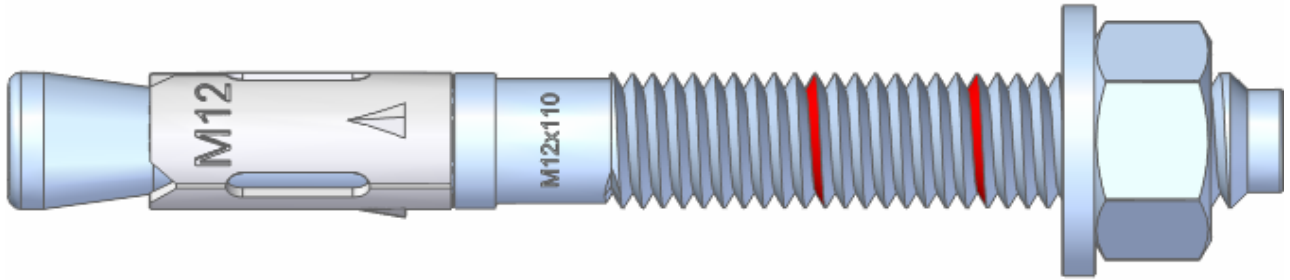

Identification on anchor:

- Expansion clip:
 - Anchor MTH: Company logo + "MTH" + Metric.
 - Anchor MTH-A4: Company logo + "MTH-A4" + Metric.
- Anchor body: Metric x Length
- Red ring marks to show embedment depths

Annex B. Materials

Item	Designation	Material for MTH	Material for MTH-A4
1	Anchor Body	Carbon steel wire rod, galvanised $\geq 5 \mu\text{m}$ ISO 4042 A2, cold forged	Stainless steel, grade A4
2	Washer	DIN 125, DIN 9021 or DIN 440 galvanised $\geq 5 \mu\text{m}$ ISO 4042 A2	DIN 125, DIN 9021 or DIN 440, stainless steel grade A4
3	Nut	DIN 934 galvanised $\geq 5 \mu\text{m}$ ISO 4042 A2, class 6	DIN 934, stainless steel grade A4
4	Expansion clip	Carbon steel strip, galvanised $\geq 5 \mu\text{m}$ ISO 4042 A2	Stainless steel, grade A4

Annex C. Installation process

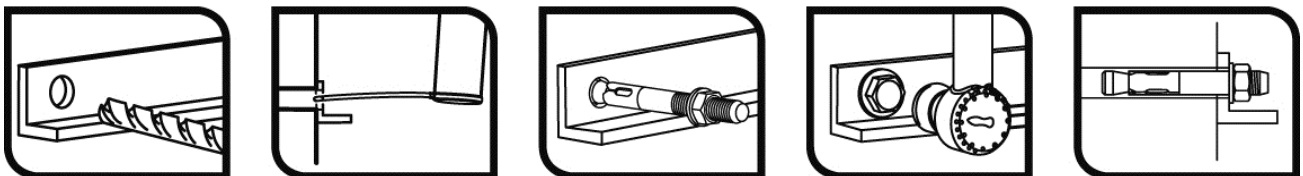

Annex D. Schema of the anchor in use

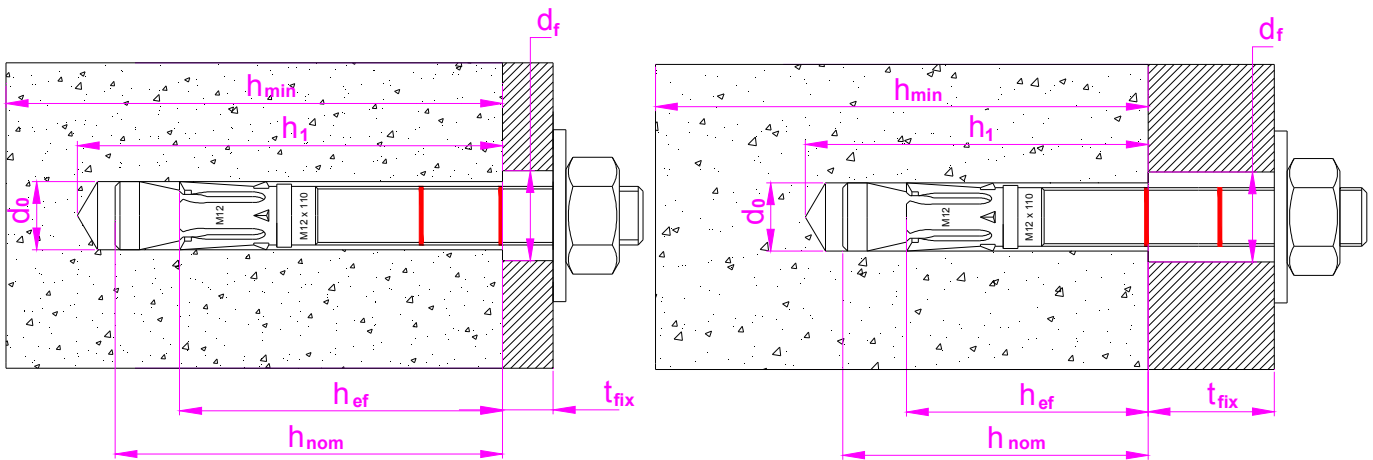

STANDARD EMBEDMENT DEPTH

REDUCED EMBEDMENT DEPTH (M8, M10 AND M12)

- h_{ef} : Effective anchorage depth
- h_1 : Depth of drilled hole
- h_{nom} : Overall anchor embedment depth in the concrete
- h_{min} : Minimum thickness of concrete member
- t_{fix} : Thickness of fixture
- d_0 : Nominal diameter of drill bit
- d_f : Fixture clearance hole diameter